



## [Exporting axial and centrifugal fans to Europe](#)

Europe is one of the largest markets for fans in the world and the market share of developing countries has increased slowly but steadily over the past five years. There are two market entry strategies that could be worthwhile to further investigate: supplying to European importers or supplying to European fan producers. In each situation, exporters from developing countries need to focus on a few special fans within their product range.

### Contents of this page

1. [Product definition](#)
2. [Geographic scope](#)
3. [Product specifications](#)
4. [Buyer requirements](#)
5. [Trade statistics](#)
6. [Market trends](#)
7. [Market channels and segments](#)
8. [Useful sources](#)

## 1 . Product definition

Fans are commonly classified as axial, centrifugal (or radial) and cross-flow fans. This survey covers axial and centrifugal fans.

Axial fans move air parallel to the shaft around which the blades spin, along the axis of rotation (Picture 1). They are used in various applications from domestic (such as ceiling fans) to industrial (such as engine cooling fans), in which a large volume of flow is required. Axial fans are typically cheaper, quieter and of a simpler construction than comparable centrifugal fans, which are generally used in applications where more pressure is required for a given air volume.

Centrifugal fans move air in a radial direction relative to the shaft (a change in direction of the airflow) and increase its pressure, using centrifugal force generated by the rotation of blades mounted at angles on the fan wheel (Picture 2). The blades of the fan wheel can be forward curved for high flow and relatively low pressure, backward curved for medium flow and high pressure, or radial for low flow and high pressure. Centrifugal fans are widely used in domestic and industrial applications requiring higher pressures, such as leaf blowers and air conditioning systems.

**Picture 1: Axial fan**

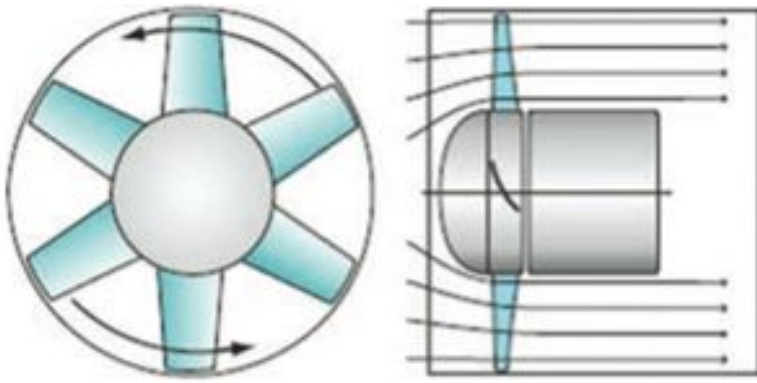

**Picture 2: Centrifugal fan**

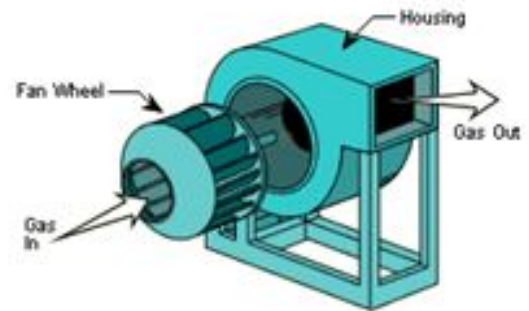

When “fans” are referred to in this survey, this concerns the products listed below, unless stated otherwise.

- CN code 84145920 (Prodcom code 28252030): Axial fans (excl. table, floor, wall, window, ceiling or roof fans with a self-contained electric motor of an output  $\leq 125$  W)
- CN code 84145940 (Prodcom code 28252050): Centrifugal fans (excl. table, floor, wall, window, ceiling or roof fans with a self-contained electric motor of an output  $\leq 125$  W)
- CN code 84145980 (Prodcom code 28252070): Fans (excl. table, floor, wall, window, ceiling or roof fans with a self-contained electric motor of an output  $\leq 125$  W, axial and centrifugal fans)

Chapter 8414 in the CN nomenclature refers to fans. Note that a few codes of Chapter 8414 were excluded from the selection, as these codes relate to applications other than the processing industry such as fans and ventilating or recycling hoods of the domestic type. Between brackets are the Prodcom codes that have been used for the production and apparent demand statistics of fans.

## 2 . Geographic scope

The geographic scope is the EU-28 area. However, in certain parts of this survey (Trade statistics, Market trends, Market channels and segments, and Useful sources), the focus is on a selected group of countries: Germany, Italy, the United Kingdom, France and the Netherlands. These countries are the largest importers of fans in Europe. When referring to ‘focus countries’ in this survey, the selection of these five countries is meant, unless stated otherwise.

## 3 . Product specifications

Specifications of fans as required by European buyers are described below. Pictures 3–6 show examples of fans sold in Europe; Picture 7 shows an example of fans ready for transport.

### Material and design

The material and design used can be in accordance with customer specifications and depend on the application. For instance, specific applications have their specific flow and pressure requirements, and some might require high rotating speeds or extreme corrosion, abrasion or temperature resistance. A standard or pre-engineered design might suffice for relatively simple application requirements, but a custom design (possibly based on a catalogue model) might be in order for applications with more complex requirements. Axial fans generally have two to six blades, whereas centrifugal fans may have a larger number of blades, especially when they are forward curved. Fan shafts, blades and housings or cases can be made of various materials such as aluminium, steel, carbon steel and plastic, with various coatings.

### Documentation

Fan importers will require associated reports about the quality and specification of the material used, registration of critical process parameters, test reports and traceability reports of the batches of products made.

## Labelling and packaging

Fans are labelled to indicate the type, batch and serial number, producer, weight, kW input, FLC, SC, and so on, of the fan. To comply with the [Ecodesign Directive 2009/125/EC](#), as well as the CE mark, the label on the fan needs to include the Fan Motor Efficiency Grade (FMEG), measurement category/installation type (A-D), efficiency category (static or total), overall efficiency of the product at its optimum energy efficiency point (Specific Fan Power, SFP) and, if applicable, confirmation that the calculation of fan efficiency is based on the use of an Inverter (VSD).

Fans can be individually packed in crates or boxes, mostly made of wood or cardboard. In addition, the packaging depends on the characteristics of the fan, such as its size. Plastics are also used for extra packaging purposes.

Note: If you use wood packaging materials to export products to Europe, you must consider health (phytosanitary) requirements set for these materials. In practice, this means that the wood must have undergone heat treatment or been fumigated with methyl bromide.

Packaging is always labelled, not only for the purposes of identification during transport but also to indicate the quantity, weight, the products themselves and the producer's name. It could very well be the case that the customer has their own additional packaging requirements and preferences. In most cases, the packaging and labelling requirements are included in the customer's specifications.

## Quality and quantity

Quality standards of individual companies vary between European countries. For instance, those in northern Europe are generally higher than those in Central and Eastern Europe. These quality standards have an effect on many issues, such as the finishing and painting of the product (the visual-optical qualities or the appearance of the fan), the requirements for the packaging, the accessory documentation, and so on.

Order volumes follow the customer's standards and requirements. As a rule of thumb, transport of standard fans from overseas countries to Europe is only viable in the case of Full Container Loads.

**Picture 3: Axial ceiling fan**



**Picture 4: Cased axial flow extract fan**



**Picture 5: Backward-bladed centrifugal fan**



**Picture 6: Forward-bladed centrifugal fan**



**Picture 7: Fans ready for transport**



## Import tariff

For fans, a [2.2% duty](#) is levied on European imports from third countries. Several countries benefit from a preferential 0% tariff; for example, Indonesia, Pakistan, Vietnam, the Philippines, Bosnia, and Egypt. This means that exporters from a country with a preferential 0% tariff have a small competitive advantage over competitors from countries without such a preferential tariff. The [TARIC database](#) shows more details relating to Chapter 8414. Note that it is only possible to claim

a preferential tariff treatment with a Certificate of Origin.

### Tip:

- Prepare a Certificate of Origin. A local Chamber of Commerce must validate it. More information can be found [here](#).

## 4 . Buyer requirements

Buyer requirements can be divided into:

1. **Musts:** requirements that you must meet to enter the market; for example, legal requirements.
2. **Common:** requirements that you need to comply with to keep up with the market.
3. **Niche:** requirements for specific segments.

### Musts

- For fans driven by motors with an electric input power between 125 W and 500 kW, the most important legal requirement is compliance with the [Ecodesign Directive 2009/125/EC \(ErP Directive\)](#), which provides consistent Europe-wide rules for improving the environmental performance of “energy-related products” (ERPs), supporting the “20-20-20 target” by reducing greenhouse gas emissions by 20%, while increasing the use of renewable energy sources by up to 20% and increasing combined fan and motor energy efficiencies by 20%, by 2020. This [FAQ](#) can be of use in transferring the Regulation and its requirements into practice.
- Fans in a potentially explosive atmosphere must meet the [ATEX Directive 94/9/EC](#). The increased clearance required by this directive may have an effect on fan performance. These fans are currently excluded from the Ecodesign Directive 2009/125/EC. However, their motor/impeller combinations do have to adhere to the existing efficiency values of Commission Regulation (EU) No 327/2011.
- Depending on their application and specifications, fans may have to comply with the [Commission Regulation \(EC\) No 640/2009 for electric motors](#), [Electromagnetic Compatibility \(EMC\) Directive 2004/108/EC](#), [Construction Products Regulation \(EU\) No 305/2011](#), [Pressure Equipment Directive \(PED\) 97/23/EC](#), [Machinery Directive 2006/42/EC](#) and [Low Voltage Directive \(LVD\) 2006/95/EC](#).

### Tips:

- Involve a [notified body](#) to certify a fan according to the European Union’s legislative requirements such as ATEX, EMC, PED or LVD. Often, such notified bodies also offer consultancy services to help producers meet the requirements. Be careful, as notified bodies are often notified only for a part of the conformity assessment procedures or only for electrical equipment, for instance.
- Consult the European Commission’s [Blue Guide](#), which is intended to explain how to implement European product rules on industrial products.

### Common

Customers often demand that suppliers work according to general organisational quality systems such as ISO 9001 (Version 2008) and process control. Sometimes, they also demand compliance with ISO 14001 (environmental) and OHSAS 18000 (labour standards).

## Niche

Basically, fans need to perform safely and reliably in any application. To perform in especially challenging industrial environments, fans may have to be abrasion-, corrosion- and temperature-resistant, to ensure safety and a long service life. Moreover, due to the larger size and relatively higher working speeds producing greater forces on their rotating structures, fans must be designed to withstand these demands.

The customers' main requirements will be related to the technical aspects of the fans; many such aspects are covered in CE or other standards. As a starting point, there are some basic standards such as ISO 12759:2010. Other standards apply to specific market segments, such as ISO 5801:2007, 5802:2001 and 12499:1999 for industrial fans. In addition, there are also standards that apply to one specific type of fan, such as ISO 27327-2:2014 for air curtain units.

The [European Association of Air Handling and Refrigerating Equipment Manufacturers](#) provides [Eurovent Certification](#), which “certifies the performance ratings of air-conditioning and refrigeration products according to European and international standards”. Some customers may prefer or require products with this certification.

### Tips:

- Design and manufacture fans for the European market with an emphasis on safety, low emissions, simple maintenance, ease of operation, and a long and reliable service life.
- Consult the ISO website for more details: [ISO Catalogue](#) - Click on “[ISO/TC 117](#)” (Fans) for an overview of ISO standards.
- Consider applying for [Eurovent Certification](#) via the instructions on their website.
- Do not underestimate the importance of customer satisfaction. Of course, customers consider good quality of the products important, but they also attach great value to compliance with delivery times and delivery volumes.

For information on buyer requirements on the European market in general, refer to [CBI's “Buyer requirements” for pipes and process equipment](#).

## 5 . Trade statistics

### Imports

In the last five years, the total value of European imports of fans grew by 4.7%, reaching €2.5 billion in 2015. The import from developing countries grew much more rapidly (by 11.4% per year), reaching €489 million in the same year.

Forecasts from leading market researchers suggest that the European market for fans and blowers will probably continue to improve in the next few years. Growth in the ventilation equipment market is likely to be driven by enhanced interest in air quality and construction activity in the residential, industrial and commercial sectors.

Figure 1: European imports of fans, by main origin  
(2011–2015)

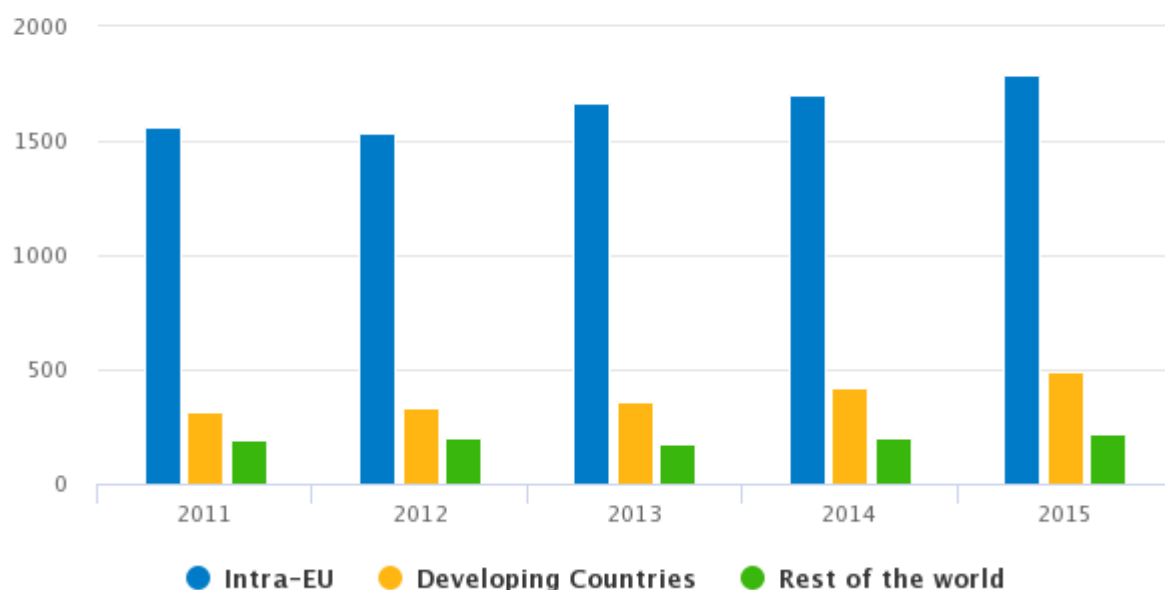

Source: ITC Trademap

Germany is the largest importer of fans, representing a total value of nearly €600 million in 2015. It is followed by the United Kingdom, France, Italy and the Netherlands.

Within Europe, the countries with the highest import growth in the last five years were Ireland (by 20% per year), Poland (11%), Hungary (10%) and Spain (10%). On average, the Central European region showed the strongest performance in terms of import growth rates.

Figure 2: European imports of fans by country, 2015, share of imported value

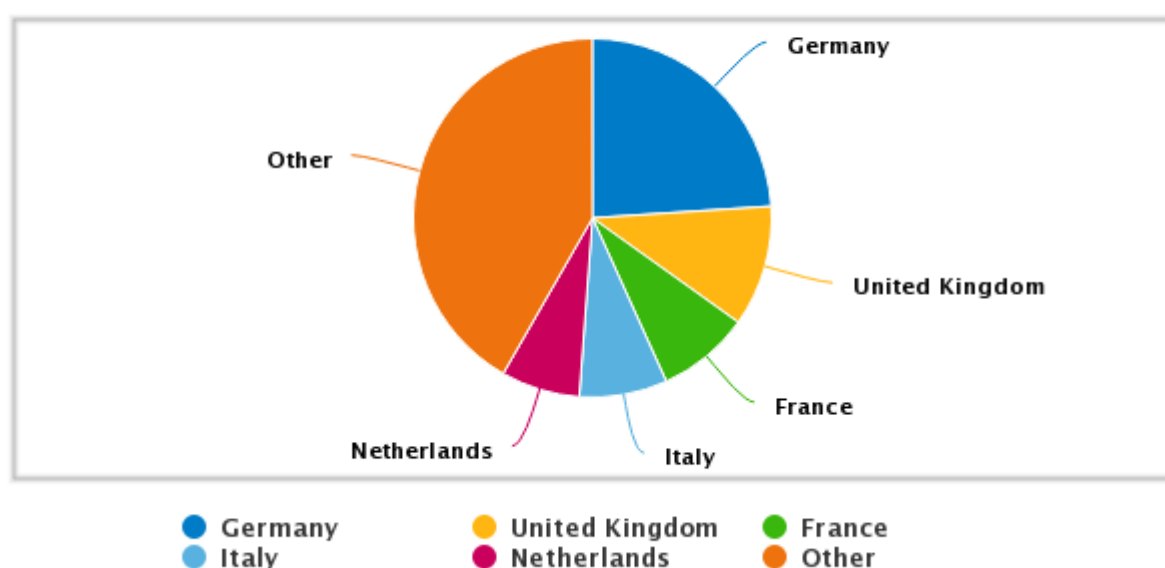

Source: ITC Trademap

### Leading suppliers

Around 12% of the total value of European fans imports originates from China. This import is dominated by the supply of centrifugal fans. Thailand is the second-largest supplier of fans from

developing countries and also mainly exports centrifugal fans to European markets.

In the list of the 20 largest suppliers of fans to Europe, the highest annual import growth in the period 2011–2015 was recorded by Thailand (by 38%), Poland (14%), the USA (12%) and Romania (10%).

Figure 3: Leading suppliers of fans to Europe, 2011 – 2015

in € euros

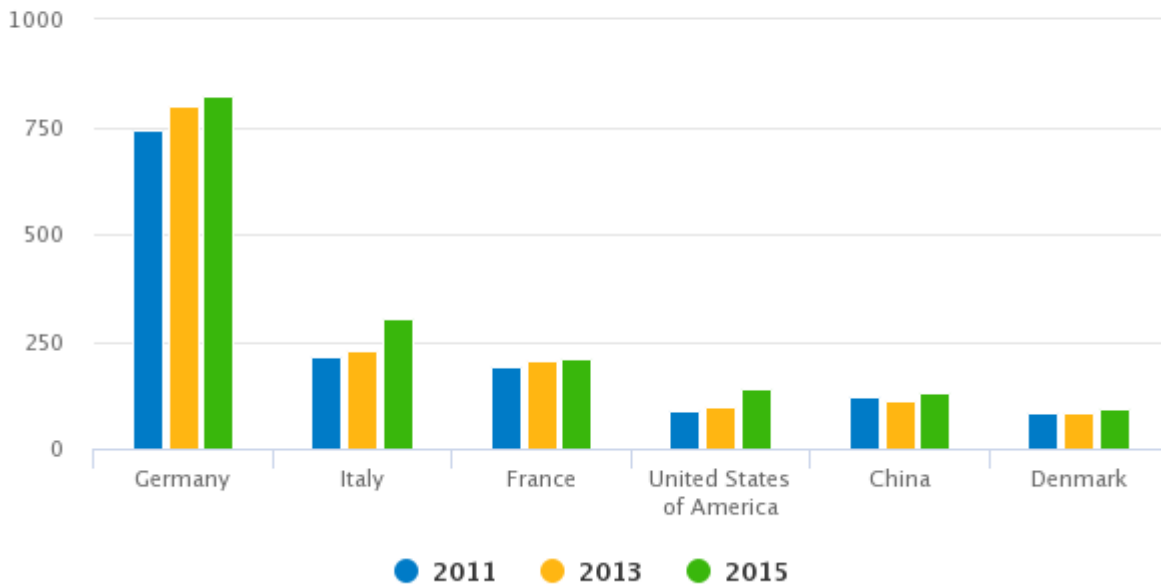

Source: ITC Trademap

### Tips:

- Identify the key importers in large or rapidly growing markets. You can start by doing an internet search or reading more about supply chains in Europe in our study of [Market channels and segments for pipes and process equipment](#).
- Learn from the largest suppliers from developing countries (China, Thailand, Malaysia and Turkey), as well as from exporters of fans from developing countries who are gaining share on the European market (such as Thailand, Philippines or Vietnam).

## Exports

European exports (including intra-European trade) of centrifugal and axial fans have grown in value by 5.2% annually since 2011, reaching €3.7 billion in 2015. Around 57% of all European exports of fans are destined for other European countries. Exports are highly concentrated; Germany alone accounts for half of the total European exports.



Figure 4: European exports of fans by country, 2015, share of exported value

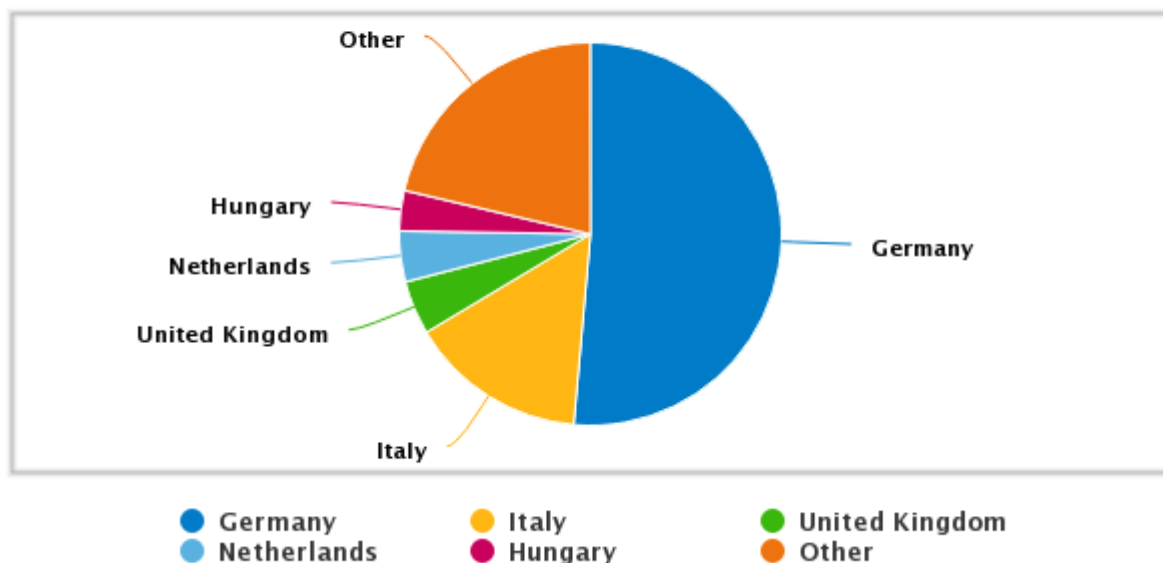

Source: ITC Trademap

The highest export growth was registered by Portugal (36% per year), followed by Slovakia (31%), Croatia (28%) and Poland (24%). However, all countries mentioned have relatively small export volumes compared to the leading European exporters.

The main export destination outside Europe in 2015 was the United States of America, followed by China, Turkey and the Russian Federation. In the list of the 20 largest destinations for European exports, the highest annual increase in exports was to Saudi Arabia (by 31% per year), South Korea (21%) and Norway (19%).

### Tips:

- Learn from European exporters and find opportunities in markets outside Europe, such as Saudi Arabia, South Korea or Norway.
- Learn more about your competitors in our study of [Competition in pipes and process equipment](#).

## Production

The total European production amounted to € 3.5 billion in 2015, following an average annual decrease of 3.2% in the period 2011-2015. Germany accounted for 48% of the total European production in 2015, followed by Italy at a huge distance.

Figure 5: European production of fans by leading countries, 2015

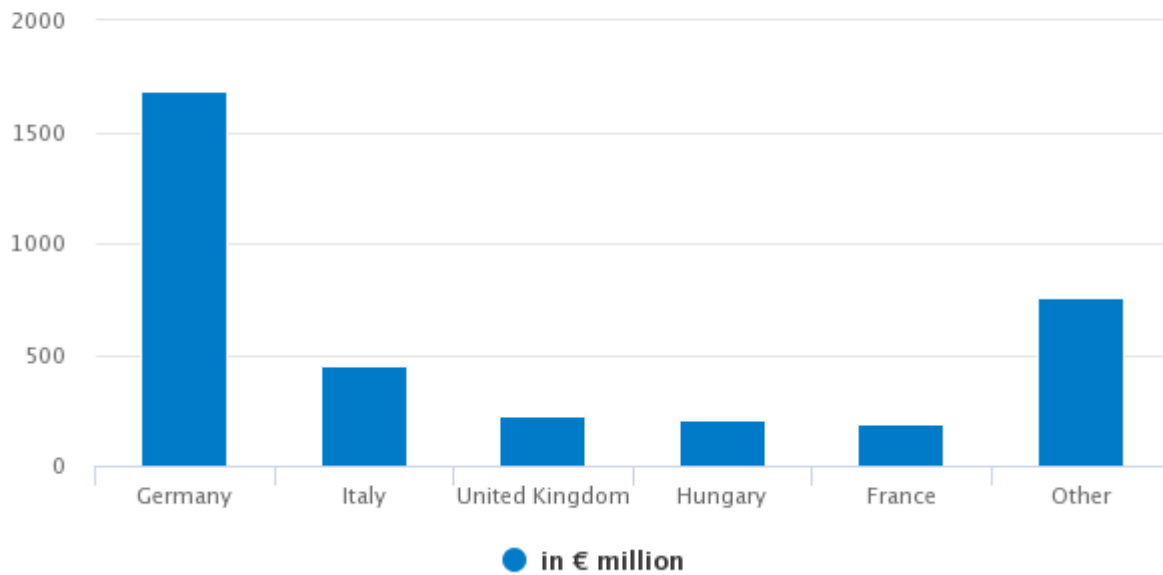

Source: Eurostat Prodcop

### Tip:

- Consider acting as a subcontractor for European producers. You can find most producers in Germany and, to a lesser extent, in Italy.

## Demand

The total European demand for fans amounted to €2.8 billion in 2015, following an average annual increase of 2.2% in the period 2011–2015. About 80% of the European market is supplied by locally produced fans (mainly from Germany). The remainder is taken up by imports from outside Europe, of which 12% comes from developing countries and 8% from other developed countries.

Figure 6: European demand for fans by leading countries, 2015

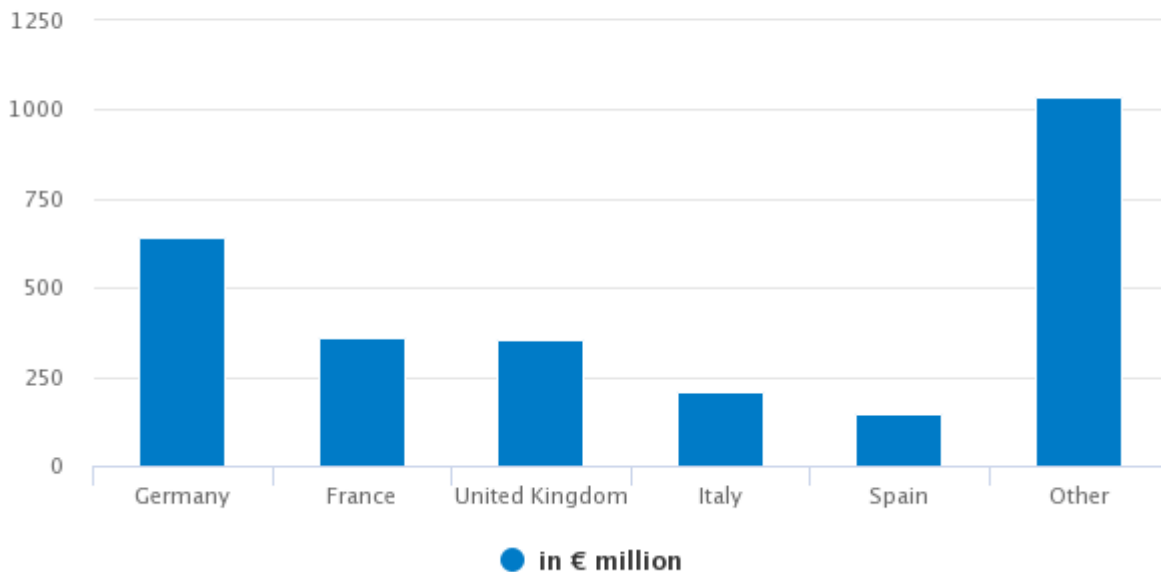

Source: Eurostat Prodcop

### Tip:

- Target importers or producers in the largest fan markets of Europe to make inroads into these markets.

## 6 . Market trends

Some of the main trends in the European fan sector are the following:

### Technological drivers

- European producers will continue to implement new technologies in order to reduce production costs and to secure their competitive edge.
- The demand for high-tech fans, which require advanced techniques of casting, working and finishing, will continue to grow in the next few years. Star performers will continue to be the highly advanced or speciality products.
- European customers will continue to require quieter fans without compromising on quality, for which EC (“electronic commutation”) motors rather than AC (alternating current) or DC (direct current) motors are becoming a popular technique. EC motors are quieter, energy-efficient and low-maintenance, with long and reliable service lives paying out in about a year compared to AC or DC motors.

### Tips:

- Supply high-tech fans.
- Supply fans with EC motors.

## Environmental drivers

Be it in domestic or industrial applications, such as sustainable building and construction, eco-friendly solutions are becoming more attractive in Europe due to environmental legislation and awareness as well as the cost-effectiveness of energy efficiency. This trend is stimulated by the adoption of the [Ecodesign Working Plan 2015-2017](#), an update of the Ecodesign Directive. It has led to the increased use of innovative production techniques, resulting in greater efficiency and less waste. Companies nowadays not only judge products on aspects such as price, quality and standards, but also on their environmental aspects. One of the effects of this trend is that eco-friendly fans have seen a rise in demand, specialising in energy efficiency, low emission and heat recovery. For example, some companies have special eco-friendly product ranges such as the [Vent-Axia Lo-Carbon range](#) and [GreenTech by ebm-papst](#).

### Tip:

- Focus on the supply of eco-friendly fans.

## 7 . Market channels and segments

The European ventilation industry consists mainly of small and medium-sized enterprises (SMEs). Such SME fan manufacturers are the most prominent targets in Europe (also see Figure 7). Producers from developing countries can become suppliers to these manufacturers as subcontractors, enhancing their opportunities by focusing on a few products that can be considered specialities. For these specialities, manufacturers are also the most important target, as some of them might be interested in subcontracting some of their production to low-cost countries. Distributors are also viable targets, as they have access to local markets in Europe.

For more information, also refer to CBI's 1) [Market channels and segments](#) and 2) [Market competitiveness](#) for Pipes and Process Equipment. The following overview is an explanation of the types of prospects, including a few examples per type. Sources for finding prospects are included in the section on "Useful sources".

Figure 7: Trade structure for axial and radial fans in Europe

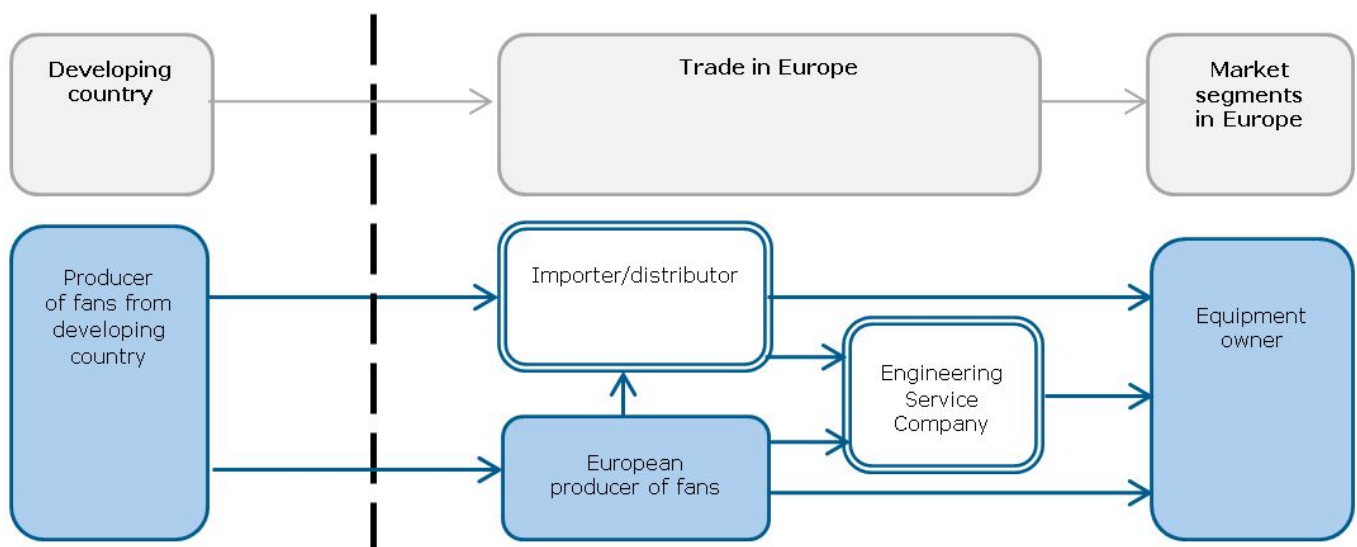

Europe is home to several interesting players. As each company is unique, with its own customers, market segments and products, the profile of the potential partner is very important. You are very likely, however, to find a match.

## Producers

These companies have strong potential for the supply of fans. Subcontracting offers the best opportunities for specialities such as special fans.

Examples of producers in the European focus countries are the following.

- Germany: [ebm-papst](#), [EVG Lufttechnik GmbH](#), [Helios Ventilatoren](#), [Maico Elektroapparate-Fabrik GmbH](#), [Rosenberg Ventilatoren GmbH](#), [Ventilatorenfabrik Oelde GmbH](#), [Witt & Sohn AG](#), [ZIEHL-ABEGG SE](#)
- Italy: [Acovent S.r.l.](#), [Boldrocchi S.r.l.](#), [CLIVET S.p.A.](#), [Comefri S.p.A.](#), [Industrie CBI S.p.A.](#), [Nicotra Gebhardt S.p.A.](#), [O.ERRE S.p.A.](#), [SagiCofim](#), [Vortice Elettrosociali S.p.A.](#)
- United Kingdom: [Airflow Developments Limited](#), [Elta Fans Ltd](#), [EnviroVent Ltd](#), [Fans & Blowers Ltd](#), [Howden Group Ltd](#), [Nuaire Group](#), [Vent-Axia Ltd](#), [Woodcock & Wilson](#)
- France: [AEIB Ventilateurs](#), [DELTA NEU](#), [ECOFIT](#), [SAFTAIR Ventilation](#), [VIM](#), [Vortice France](#)
- Netherlands: [Bosa Ventilatoren b.v.](#), [COMBIMAC B.V.](#), [Induvac B.V.](#), [Itho Daalderop](#), [LUTEC Luchttechniek BV](#), [Naaykens Luchttechnische Apparatenbouw BV](#), [Vostermans Ventilation B.V.](#)

Please note that this enumeration is not exhaustive and is only meant to be illustrative of a certain category of companies.

## Distributors

Distributors are attractive targets for exporters from developing countries whose aim is to export large volumes of standard or predesigned fans, because distributors often buy and/or import commodities in relatively large quantities on a scheduled basis. Usually, the distributor is also the importer. Distributors often have their own stock, which is the reason that they are also called “stockists”. Products need to be kept in stock, as they have to be available to end-users in the event of an urgent delivery. Most distributors offer a selection of fans and other ventilation-related equipment for a wide range of industries.

Some examples of distributors are the following.

- Germany: [ACF Ventilatoren GmbH](#), [Breuell & Hilgenfeldt GmbH](#), [Klimapartner Haustechnische Handels-GmbH](#), [RC-Technik Ventilatoren-Vertriebs GmbH](#)
- Italy: [Green Termal Systems s.r.l.](#), [Lufta s.r.l.](#), [Tecnodelta s.r.l.](#)
- United Kingdom: [Axair Fans UK Ltd](#), [Just Fans Ltd](#), [Northern Fan Supplies LTD](#)
- France: [Deressy Charlas](#), [ETN](#), [MVI](#), [VIF Equipment](#)
- Netherlands: [AirFan B.V.](#), [DE WIT ventilatoren BV](#), [Van Spijk B.V.](#), [Ventilatorenwebshop.nl](#)

Please note that this enumeration is not exhaustive and is only meant to be illustrative of a certain category of companies.

## Engineering service companies

Engineering service companies, or “contractors”, build and/or maintain and repair machinery and/or plants that contain fans. They only buy from respected brand manufacturers in developing countries and their customers are equipment owners. Note that these equipment owners may own and manage installations all over the world and could allocate installation or maintenance projects for any of these installations to the European engineering service company. A large part of a service company’s activities, engineering, procurement and commissioning takes place in Europe, while actual installation takes place directly at the relevant location anywhere in the world.

## 8 . Useful sources

For each focus country, there are several useful sources listed below.

### Germany

- Finding prospects: [German Commercial Agents Directory](#), [VDMA market](#), [Wer liefert was?](#)
- Associations: [BDI](#), [Fachverband Gebäude-Klima e. V.](#), [Herstellerverband Raumluftechnische Geräte e.V.](#), [VDI-Gesellschaft Bauen und Gebäudetechnik](#)

- Magazines and news: [Chemie Technik](#), [HLH](#), [Industrie](#), [Industrie Anzeiger](#), [Scope](#), [Springer VDI Verlag](#)
- Trade fairs: [Chillventa](#), [Cleanzone](#), [Hannover Messe](#), [ISH Aircontec](#), [IFH/Intherm](#), [Light + Building](#), [SHKG](#)

## Italy

- Finding prospects: [Azienda in fiera](#), [FNAARC](#)
- Associations: [AiCARR](#), [ASSOCLIMA - Manufacturers of Air-conditioning Systems](#).
- Magazines and news: [AiCARR Journal](#)
- Trade fairs: [Clima Expo Roma](#), [Klimahouse](#), [Mostra Convegno Expocomfort](#), [Saie Building Innovation Exhibition](#)

## United Kingdom

- Finding prospects: [Applegate Directory](#), [Hotfrog](#)
- Associations: [Building & Engineering Services Association](#), [Chartered Institution of Building Services Engineers](#), [Federation of Environmental Trade Associations \(Heating, Ventilating and Air Conditioning Manufacturers' Association\)](#), [Fan Manufacturers' Association](#)
- Magazines and news: [CIBSE Journal](#), [Heating and Ventilating Review](#), [ConnectingIndustry.com](#), [Modern Building Services](#)
- Trade fairs: [Ecobuild](#), [Facilities Show](#), [London Build Show](#), [MACH](#), [Subcon](#)

## France

- Finding prospects: [Hotfrog](#)
- Associations: [AFM](#), [AICVF](#), [Uniclimate](#)
- Magazines and news: [Axes Industries](#), [CVC](#), [Industrie & Technologies](#), [Usine Nouvelle](#)
- Trade fairs: [Climamed](#), [Fan](#), [Industrie](#), [Midest](#), [Pollutec](#), [Sepem Industries](#)

## Netherlands

- Finding prospects: [Products 4 Engineers](#)
- Associations: [VLA](#), [FME](#), [KNVvK](#)
- Magazines and news: [Engineersonline](#), [Metaalmagazine](#), [RCCK&L](#), [Technisch Weekblad](#)
- Trade fairs: [ESEF](#), [Industrial Processing](#), [Techni-Show](#), [Technische Industriële Vakbeurs](#)

## Other general sources

- Finding prospects: [ABC Business Directories](#), [Europages](#), [Kompass](#)
- International associations: [Air Movement and Control Association \(AMCA\) International](#), [European Ventilation Hygiene Association](#), [European Ventilation Industry Association](#), [Federation of European Heating, Ventilation and Air Conditioning Associations](#)
- International magazines and news: [inmotion](#), [REHVA European HVAC Journal](#)
- Trade fair databases: [AUMA](#), [Eventseye](#), [toFairs.com](#)
- Trade statistics: [Eurostat](#), [ITC International Trade Statistics](#)
- Other: [EU Export Helpdesk](#), [Kwintessential](#)

Please review our [market information disclaimer](#)

Follow us for the latest updates

[Twitter](#)

[Facebook](#)

[LinkedIn](#)

[RSS](#)